

# MARKET LEADERS IN FILTRATION

## RONA™ MEMBRANE HSG

DEPTH FILTER

Housing

Standard Surface finishing is RA<08 roughness. The design meets most common processing requirements for Food, Beverage, Chemical and Pharma applications.



### FEATURES

- Highflow applications
- Commercial
- Industrial
- Reverse osmosis pre-filtration
- No warp or weep
- UV rays or sunlight don't effect housing
- Precision made
- Mechanical polished
- Pressure gauge and other accessories available
- Stainless steel 316 food grade
- Pressure testing available
- Clap locking available

### APPLICATIONS FOR PRODUCT

- Lenticular housing units are used in a broad range of applications from the filtration of distilled spirits, wines, beers and the clarification of fruit juices
- They are also used in the pharmaceutical, cosmetic and chemical processing industries.

*NOTE: Customising and other sizes are available.  
Including skid mountable.  
Ask your friendly sales representative for assistance.*

### OPERATING CONDITIONS

WORKING CONDITIONS CE 97/23	MAX PRESSURE BAR						
	FLUID GROUP	STATE	TEMP	SH 011	SH 012	SH 013	SH 014
DA	DANGEROUS	L	0 - 40°C	10	10	10	10
DA	DANGEROUS	L	150°C	7.5	7.5	7.5	7.5
DA	DANGEROUS	G,V	0 - 40°C	10	10	7.4	5.8
DA	DANGEROUS	G,V	150°C	7.5	7.5	7.4	5.8
DA	NOT DANGER.	L	0 - 40°C	10	10	10	10
DA	NOT DANGER.	L	150°C	7.5	7.5	7.5	7.5
DA	NOT DANGER.	G,V	0 - 40°C	10	10	10	10
DA	NOT DANGER.	G,V	150°C	7.5	7.5	7.5	7.5
DA	INTEGRITY TEST			10	10	10	10

L = LIQUID, G = Gas, V = VAPOR

### MATERIALS OF CONSTRUCTION

**Vessel Material:** 316L / 1.4404

**Seals Material:** Silicone FDA BGA Approved

**Internal Finishing:** Mechanical Polishing

**Internal Roughness:** Ra<0.8 Micron

**External Finishing:** Mechanical Polishing



## MEASUREMENTS

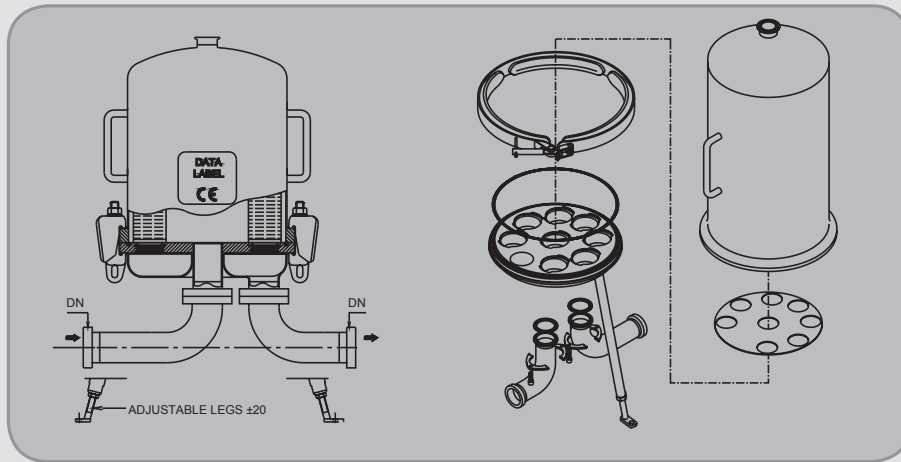

## OPTIONAL ACCESSORIES

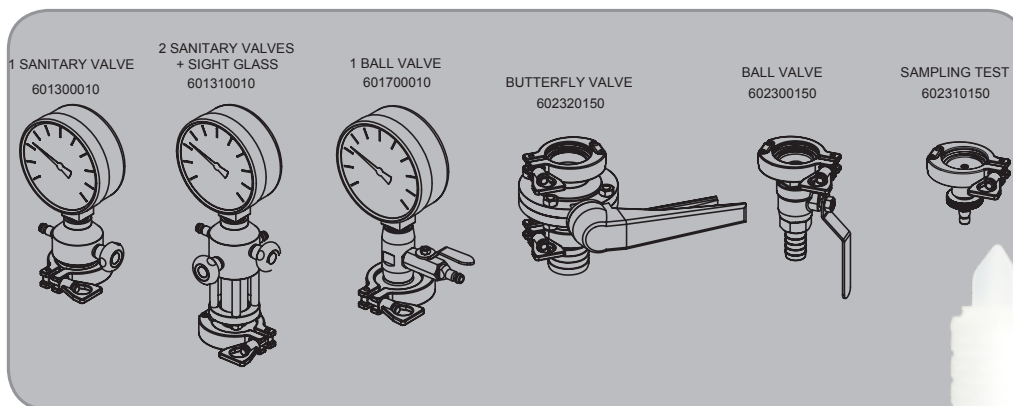

## ORDERING INFORMATION

RANGE	END FITTING	CARTRIDGE HEIGHT	DN			
<b>501</b>	<b>200:</b> Open end with flat gaskets	<b>1:</b> 10"	2.0"	<b>1051</b> (Weld 2.0")	<b>3051</b> (Clamp 2.0")	<b>4051</b> (RJT Male Part 2.0")
	<b>203:</b> Open end with (2) O-ring 222 blind end with flat top	<b>2:</b> 20"	2.5"	<b>1063</b> (Weld 2.5")	<b>3063</b> (Clamp 2.5")	<b>4063</b> (RJT Male Part 2.0")
	<b>207:</b> Open end with (2) O-ring 226 and 2 bayonet locks. Blind end with fin	<b>3:</b> 30"	3.0"	<b>1076</b> (Weld 3.0")	<b>3076</b> (Clamp 3.0")	<b>4076</b> (RJT Male Part 2.0")
	<b>208:</b> Open end with (2) O-ring 222 blind end with fin	<b>4:</b> 40"	4.0"	<b>1107</b> (Weld 4.0")	<b>3101</b> (Clamp 4.0")	<b>4101</b> (RJT Male Part 2.0")
	<b>212:</b> Open end with (2) O-ring 222 blind end with flat top					
	<b>208:</b> Open end with (2) O-ring 222 blind end with fin					
	<b>212:</b> Open end with (2) O-ring 222 blind end with flat top					

Australia Office:

P: +61 (0) 3 9872 6811

F: +61 (0) 3 9872 6822

E: Feedback@progressivegroup.com.au

17 Redland Drive, Mitcham, 3132, Victoria, Australia

www.progressivegroup.com.au

New Zealand Office:

P: +64 (0) 9 951 3142

F: +64 (0) 9 951 3143

E: Feedback@progressivegroupnz.co.nz

17B Farnham Street, Parnell, Auckland, 1052, New Zealand

www.progressivegroupnz.co.nz

